

**OPERATING
INSTRUCTIONS**

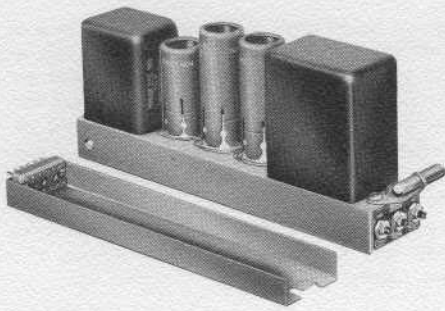

459A PROGRAM AMPLIFIER

SPECIFICATIONS

Gain: 56 db unterminated input, 50 db terminated.
Power: +30 dbm at less than .5% THD 30 to 20,000 cps.
Frequency: +35 dbm at less than 1% THD at 1 KC.
Response: ± 1 db. 20 to 20,000 cps.
Source Impedance: 150 or 600 ohms (centertap available when connected for 600 ohms).
Load Impedance: 150 or 600 ohms (centertap available when connected for 600 ohms).
Equivalent input noise: -126 dbm (valid for unterminated input operation).
Power Supply: 40ma at 275vdc and 1.6a at 6.3vdc.
Tubes: 1-6072/12AY7, 2-12BH7.
Dimensions: $1\frac{3}{4}$ " W x $3\frac{15}{16}$ " H x $9\frac{11}{16}$ " L when mounted in tray. (See Fig. 1).
Color: Cad plate, dichromate dip.
Weight: $3\frac{1}{2}$ lbs. (including tray).
Special: Push buttons for individual tube test.
40ma dc can be applied to input or output transformer center taps for simplexing use.
Accessories: 13225 Rack Mounting Assembly (accommodates 9 units).
13401 Mounting Tray Assembly.
5981 Tube Test Meter.
535A Power Supply.

CIRCUIT DESCRIPTION

The 459A is a highly reliable, low noise program amplifier with an exceptionally large power capability. It consists of a two-stage, push-pull circuit having a balanced negative feedback loop. Push-pull operation of all stages provides reliability, interchangeability and power supply simplification as outlined below. Superior overall performance is made possible through the use of specially designed input and output transformers having very accurate balance and a large ratio of primary inductance to leakage reactance.

RELIABILITY

Program transmission is not interrupted by failure of either output tube. The single input tube is a premium quality type which has been pre-aged to eliminate early failures. It is a dual triode type which has parallel rather than series heater sections. Because of the push-pull connection and the heater arrangement, failure of either heater section will not cause program interruption. Such failures cause a minor loss of output and a narrowing of the band-width by about an octave at each frequency extreme, allowing continued operation and repair at a convenient time.

To enhance tube life, heat-reducing tube shields are employed to keep bulb temperatures to the lowest possible degree. This precaution inhibits "getter" migration and cathode evaporation, both of which tend to cause an increase in noise as tubes age.

**RECEPTACLE CONNECTIONS
(Mounting Tray)**

Input	Connect to 2 and 8	Strap 4 to 6 for 600 ohms (4-6 is center tap). Strap 2 to 4 and 6 to 8 for 150 ohms.
Output	Connect to 1 and 7	Strap 3 to 5 for 600 ohms (3-5 is center tap). Strap 1 to 3 and 5 to 7 for 150 ohms.
B+	Connect to 12	(Requires grounding at single point.) (One side requires grounding at single point.)
B-	Connect to 10	
Heater (6.3vdc)	Connect to 11 and 15	
Meter+	Connect to 9	
Meter-	Connect to 10	
Chassis Ground	Connect to 13	

INTERCHANGEABILITY

The 459A electrical connections, impedances and physical size are compatible with the 458A permitting substitution, assuming the power supply has the added current capability. This is of advantage when a channel containing a 458A requires additional gain. A boom-microphone channel of a speech input system, for instance, can realize a 16 db increase in gain in no more time than is required to unplug one and insert another amplifier in the mounting tray.

IMPEDANCE

(Source and Load)

Both 150 and 600 ohm source and load impedances are available at the connector so that socket wiring changes, or strapping within the amplifier is not required. By this means, any amplifier is correctly matched when inserted into any tray properly wired for its particular function.

INTERNAL OUTPUT IMPEDANCE

Unlike the 458A, the 459A program amplifier has an internal impedance which is low compared to its nominal load impedance. This is an advantage in feeding long lines and provides additional isolation between outputs when used to feed branching networks.

INPUT TERMINATION

The 459A has an unterminated input transformer making it suitable for use with microphones. In its normal function as a line amplifier, however, it should be terminated. A 150 or 600 ohm resistor must be connected to the mounting-tray receptacle for this purpose. In this way, all amplifiers are interchangeable in mounting trays regardless of termination. Under no circumstances should termination be attempted at the secondary of the input transformer.

METERING

Push-button switches are provided on the amplifier and wired to the plug for use with an external meter. Connector pin 9 is multiplied to any number of amplifiers and to the meter + terminal. B - (pin 10) is connected to the meter- terminal. Pressing buttons on any amplifier will give an indication of tube space current. Average reading is 67% of full scale on a 0 to 200 microampere meter having an internal resistance of approximately 1000 ohms. The ALTEC 5981 meter is recommended and suitably marked for this use.

POWER REQUIREMENTS

The 459A ratings are based upon a "B" supply of 275 volts at 40 ma; however, the exact value is not critical. With a 225 volt supply the unit draws 34 ma and the distortion at 1 KC increases to .45% at +30 dbm. The amplifier is designed to operate from 6.3 volt, .7 amp DC heater supply. If for any reason an AC supply must be used in low noise applications, it will be necessary to twist and re-route the heater leads within the amplifier as well as exercising care in wiring the receptacles on the mounting trays.

Because of push-pull circuitry, 459A's and 458A's fed from a common power supply may be cascaded without danger of coupling through the power supply.

SERVICING

Maintenance should consist solely of replacing tubes when the cathode current shows a significant drop. Severe unbalance between V2 and V3 will cause an increase in distortion at full output in the 20 to 30 cycle region. Resistors used in critical locations are of precision types, having adequate power capability to withstand overloads caused by tube failure. The feedback network, composed of R2, R3 and R10, R11 is balanced and direct-coupled. Because of the direct-coupling, this network provides part of the bias potential for V1. If for any reason the feedback network is to be opened for measurement, resistors R2 and R10 must be removed from the plates of V2 and V3 and connected to B+ at the output transformer center tap. In this way, proper biases will be maintained. Because of their tight fit, tube shields must be removed with care to avoid bending the tube pins. Do not relieve the tube shield fit as it will impair its effectiveness in reducing bulb temperature.

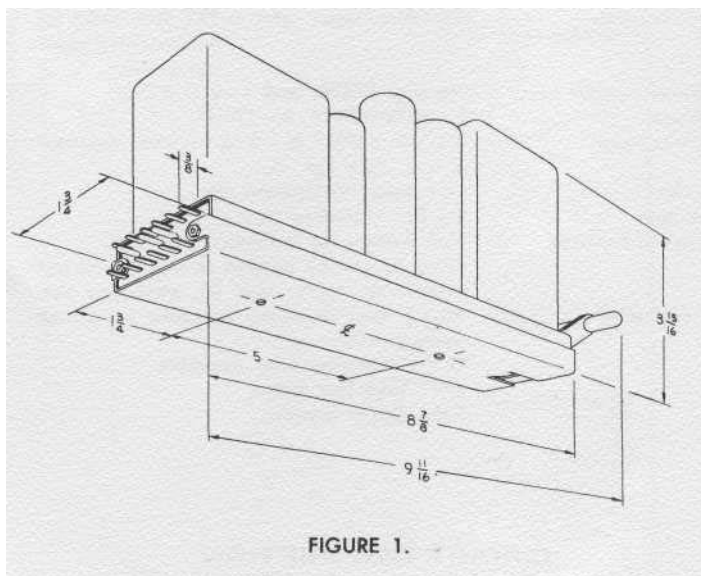
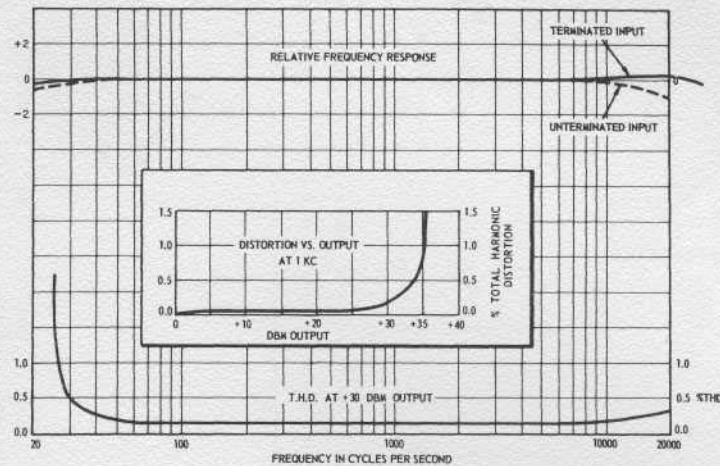

FIGURE 1.

PERFORMANCE

459A PROGRAM AMPLIFIER



ACCESSORIES

535A POWER SUPPLY



13225 RACK MOUNTING



13401 MOUNTING TRAY



SPECIFICATIONS

Power Output:	275vdc at 275 ma. At 275ma ripple is .02v peak to peak max. 6.3vdc at 13a. At 13a ripple is 1.5v peak to peak max.
Power Input:	117v 50-60 cps 245 watts at full load.
Rectifiers:	Silicon.
Controls:	<ol style="list-style-type: none"> 1. Power Switch 2. Circuit Breaker (Push to reset). 3. 4 Position tap switch (provides adjustment of voltage by autoformer action to accommodate 2 to 1 range of loads).
Color:	Dark Green.
Weight:	16 pounds.
Size and Mounting:	7 ³ / ₁₆ " W x 9 ⁵ / ₈ " H x 7" D overall.

13225 Mounting is available for use in rack mounting of speech input equipment. The rack mounting assembly is drilled to accept nine type 13401 Mounting Tray Assemblies for use with Altec 458A and 459A "Plug-In" Amplifiers and Altec 13387 Utility Input Device. The 13225 assembly is for standard 19" rack or equipment cabinet mounting and occupies only 5¹/₄" of panel space. The assembly has a "Snap-in" removable front cover for instantaneous access to the units for test or service. The finish of the front cover is Dark Green, and the complete assembly weighs 4 pounds. For rack mounting 535A Power Supply, 10440 10¹/₂" Blank Panel may be used or Power Supply may be mounted on wall of equipment cabinet.

13401 Mounting Tray is furnished as part of the 250 SU Altec Control Console, however, it is available separately to provide mounting and "plug-in" connection facilities for 458A and 459A Altec "Plug-In" Amplifiers or the 13387 Utility Input Device, when mounted in the 13225 Rack Mounting Assembly. The 13401 finish is cadmium plate with dichromate dip. The tray assembly is complete with "mating" female receptacle to accept the 458A, 459A and 13387 units. The tray measures 1³/₄" W x ⁷/₈" H x 9" L (over terminals), and weighs ¹/₂ pound.

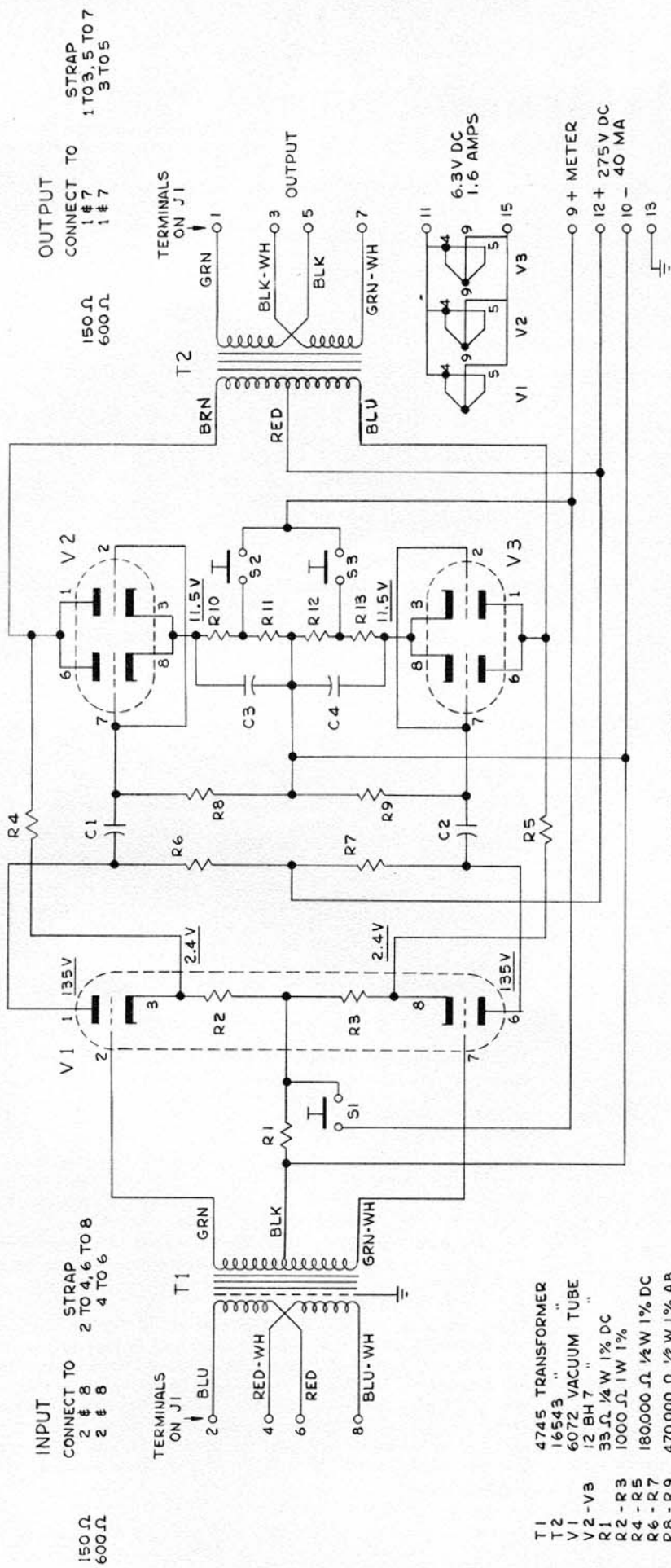

ALTEC LANSING
459A AMPLIFIER

- T1 4745 TRANSFORMER
- T2 16543 "
- V1 6072 VACUUM TUBE
- V2-V3 12 BH 7 "
- R1 33.Ω 1/2 W 1% DC
- R2-R3 1000 Ω 1W 1%
- R4-R5 180,000 Ω 1/2 W 1% DC
- R6-R7 470,000 Ω 1/2 W 1% AB
- R8-R9 600 Ω 1W 1%
- R10-R13 7.5 Ω 1W 3%
- C1-C2 .022 MFD 400V
- C3-C4 25 MFD 15V
- S1-S2-S3 GRAYHILL 30-1
- J1 AMPHENOL 126-151

INPUT
CONNECT TO
2 # 8
2 # 8

STRAP
2 TO 4, 6 TO 8
4 TO 6

150 Ω
600 Ω

OUTPUT
CONNECT TO
1 # 7
1 # 7

STRAP
1 TO 3, 5 TO 7
3 TO 5

150 Ω
600 Ω

TERMINALS
ON J1

FIRST MADE FOR
TOLERANCES EXCEPT AS NOTED, FRACT. ± 1/64" DEC. ± .005" HOLE SIZES 0 TO 1/8" ± .001 OVER 1/8" ± .005 ANGULAR ± 1/2°

ISSUE	APPROV'D	DATE	CHANGE
2	DA	6-24-66	REVERSED BLU-BRN, T2

ALTEC
LANSING CORPORATION
ANAHEIM, CALIFORNIA

459A AMPLIFIER
SCHEMATIC

DR. BY FLG 7030-2