



ALTEC
LANSING

438C AMPLIFIER

OPERATING INSTRUCTIONS



SPECIFICATIONS

Type:	Compressor Amplifier	Attack Time:	50 milliseconds
Gain:	90 db from microphone input; 40 db bridging 600 ohm line	Release Time:	Adjustable: .3 seconds to 1.3 seconds (63% recovery)
Frequency Response:	±1.5db, 40-10,000 cycles	Threshold:	Adjustable: 0 dbm to +16 dbm output
Power Output:	+24 dbm as straight amplifier	Compression Ratio:	2:1 at 0 dbm threshold; 4:1 at +16 dbm threshold
Harmonic Distortion:	At 25 db of compression: Less than 1.5%, 35 to 15,000 cycles; At 30 db of compression: Less than 2.5%, 35 to 10,000 cycles (0 db Threshold Control setting)	Controls:	Gain, Threshold, Release Time, AC Power Switch
Noise Level:	Gain control at maximum: -119 dbm equivalent input noise, microphone input; Gain control at minimum: -50 dbm output noise level	Power Supply:	115 volts, 60 cycles
Input Impedance:	Bridging: 20,000 ohms, unbalanced	Power Consumption:	22 watts
Source Impedance:	Microphone input: 150/250 ohms (30/50 ohms operation optional)	Tubes:	12AY7, 6BC8, 6CG7, 6AL5
Load Impedance:	150 and 600 ohms	Dimensions:	19" W; 3-1/2" H; and 6" D
Maximum Compression:	30 db	Color:	Dark Green
		Weight:	8 1/2 lbs.
		Special Features:	Compression meter; shaft locks for Threshold and Release Time Controls.
		Accessories:	12495 Cabinet

DESCRIPTION

The 438C Compressor Amplifier is capable of driving any Altec power amplifier to full output from a low impedance (150/250 ohms) microphone while simultaneously providing up to 30 db of compression. The unit operates from 115 volts, 60 cycles AC and occupies 3 1/2" of standard rack mounting space; all controls and indicators are mounted on a hinged front panel. The 438C is provided with two inputs: A micro-

phone input, equipped with an input transformer, and a bridging input of 20,000 ohms impedance; output loads of 150 or 600 ohms may be accommodated.

The attack time of the 438C is a fixed value of 50 milliseconds; the threshold, amount of compression, and release time are variable in order to provide maximum versatility.



A Division of *LSV* Ling Altec, Inc.
©Altec Lansing

1515 S. Manchester Ave., Anaheim, Calif.
New York

14293-2 Price \$.14
Litho in U.S.A. C/P 11/65

APPLICATIONS

The 438C is intended for use in automatic level control applications, fulfilling the requirements of sound recording, radio and television broadcasting, and public address systems. Variations in output levels may be greatly minimized by usage of this compressor amplifier.

The bridging input permits the 438C to be employed to control differences in level between two or more program sources; in addition, the unit may be used to provide 'automatic fading'¹ for systems requiring voice-over-music announcements. In industrial applications, wherein sudden high level sounds may cause 'blasting,' with attendant danger to amplifiers and loudspeakers, the 438C will prevent such overloading.

The 438C may be used as a 'straight,' high-quality line amplifier (or microphone preamplifier), without any compression action, simply by removing the 6AL5 tube from its socket.

INSTALLATION

The accompanying figures illustrate several system arrangements, using the 438C compressor amplifier as a preamplifier/line amplifier and as a line amplifier only. The microphone input will accommodate a substantial range of microphone impedances. Units are shipped for 150/250 ohm operation but the input transformer may be wired for 30/50 ohm operation in accordance with the schematic. For simultaneous usage of the bridging and microphone inputs, the source connected to the bridging input must be at least 40,000 ohms or a build-out resistor of that value employed. Under this condition, the gain from the microphone input is reduced a maximum of 3 1/2 db.

By utilizing only the bridging input, the 438C may be connected into any high or low impedance, unbalanced line between preamplifiers and power amplifiers without the need for a build-out resistor, adapters, or other modification, and without the need to add an input gain control.

With high-impedance lines, as exemplified by the Altec 1566A, 1567A, the Custom Series and similar preamplifier/mixer components, the bridging input of the 438C provides a suitable load into which these units may operate. The output of the 438C, when terminated with 600 ohms resistance, is of sufficient level to operate directly into the high impedance input of the power amplifier.

The output transformer of the 438C provides load impedances of 150 and 600 ohms and is well balanced. Because of the transformer configuration and the amplifier power capability, it is suitable for directly feeding transmission lines or combinations of one or more power amplifiers.

Input-output characteristics are shown in more detail on the accompanying 'transfer graph' for three settings of the threshold control.

NOTE: Since the outputs at high values of compression will overdrive most power amplifiers, it may be necessary to install a suitable loss pad at the input of those power amplifiers not equipped with an input gain control.

OPERATION AND USE OF CONTROLS 1:

Input Gain Control:

This control affects the levels of both channels (i. e., bridging and microphone inputs) and is used to adjust the input

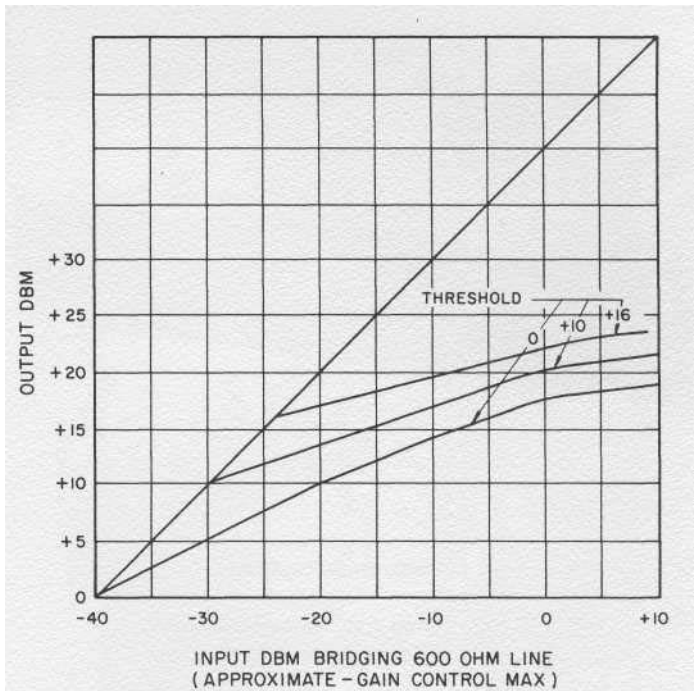

level to provide the desired average compression as indicated on the compression meter.

2: Threshold Control:

The output level, at which compression commences, together with the compression ratio, is adjustable by means of this control. In the maximum counter-clockwise position, compression begins when the output is approximately zero level. An increase in input level of 20 db at this point results in an output level increase of 10 db, giving a compression ratio of 2:1.

At maximum clockwise rotation, compression starts when the output of the 438C is approximately +16 dbm. An increase in input level of 20db at this point results in an output level increase of 5 db, giving a compression ratio of 4:1. (Maximum compression before distortion is 22 db at this setting.)

The higher threshold and flatter output characteristic may be more desirable in applications, such as the recording of sound, where the adjustment can be such that the majority of the material operates the amplifier in the linear transfer region and the occasional peak is compressed sufficiently (by the higher compression ratio) to prevent overmodulation of the recording mechanism.

Conversely, for background music control, where the compressor function is to equalize differences in recording level and program dynamics, the zero level threshold and 2:1 ratio are more desirable. In this application, "average" level material is used to set the compressor for 10 to 15 db of compression; expansion or compression then results for material of lower or higher level than the standard "average."

3: Release Time Control:

The time interval required to restore full gain, following a condition of compression, is adjustable in the range of .3 seconds to 1 .3 seconds by means of this control. In applications such as sound recording, where only an occasional peak actuates the compressor, the faster release times will be found desirable.

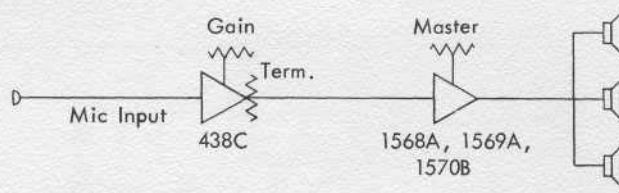

Figure 1: 438C Compressor Amplifier driven by low impedance microphone and driving any Altec power amplifier without added transformer. A 600-ohm terminating resistor must be connected across the 438C output for amplifiers shown. Add fixed or variable attenuation ahead of Altec 260A amplifier.

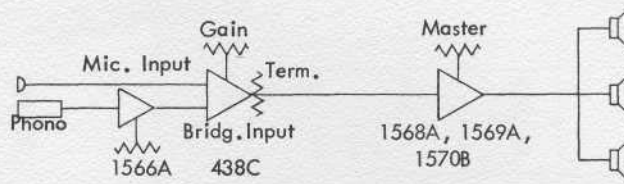

Figure 2: 438C driven by both microphone and phono circuit for voice-over-music operation. Use build-out resistor of 47,000 ohms at output of 1566A.

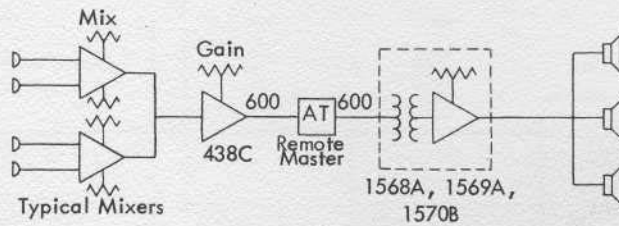

Figure 3: Typical system using bridging input of 438C. The remote master provides proper termination for the 438C and the transformer provides additional gain for the power amplifier.

For public address usage, where the compressor is utilized as an averaging device to compensate for variations in microphones and speech levels, the longer release time will be found advantageous.

4: AC Power Switch:

This control operates the power switch (Altec 12180-1), turning the compressor amplifier on and off, as indicated by the front panel pilot light.

CONTROL LOCKS

Both the threshold and release time controls are of the screw-driver adjustment type and are mounted flush with the front panel. A 1/2" open-end wrench is required for loosening and tightening the shaft locks before and after adjustment. The

front panel must be dropped to gain access to the control locks.

COMPRESSION METER

It is usually desirable to have the compression meter visible from the operating position. When conditions dictate a remote location for the compressor amplifier, an Altec 6049 meter is connected in parallel with the front panel meter by means of a pair of wires extended to the console location.

SERVICING

All circuit components are easily reached by opening the hinged front panel of the unit. Normal servicing may be done with a voltmeter; all pertinent information is shown on the accompanying schematic.

438C AMPLIFIER — PARTS LIST

C1	50 mfd, 3v CD BBR 50-3	R20	8,200 ohms, ±10%, 1/2 watt 7,000
C2	.047mfd, 400v Micamold Tropicap	R21	ohms, ±10%, 1 watt
C3	.005mfd, 600v GMV Disc, Erie 811		
C4	.5mfd, 200v, Hopkins 15-390-7A (P52DS)	T1	Input transformer, Altec K-308D
C6, 7,8,9	.0022 mfd, 400v Micamold Tropicap	T2	Interstage transformer, Altec 4651A
C10	1 mfd, 200v; Hopkins 15-390-3 (1 P2D)	T3	Output transformer, Altec 16402
C11	40-40-20 mfd, 450v, Mallory FP 376.9	T4	Power transformer, Altec 6216
C12 , 13	100 mfd, 150v, Mallory FP 116		
R1	82,000 ohms, ±10%, 1/2 watt	P1	Pot. Altec 12178-1
R2	3,900 ohms, ±10%, 1/2 watt	P2	Pot., Altec 14289-1 1 meg ohms
R3	240,000 ohms, ±10%, 1/2 watt	P3	Pot., Altec 14288-1 25,000 ohms
R4, 11,12	1 megohm, ±10%, 1/2 wa11		
R5	1,800 ohms, ±10%, 1/2 watt	M1	Meter, Altec 6049
R6	100,000 ohms, ±1 0%, 1/2 watt	PL1	Pilot lamp, Mazda #44
R7, 8,9,10	47,000 ohms, ±1% (Dep. carbon)	F1	Fuse, 1/2 ampere, 3AG
R13	220 ohms, ±10%, 1/2 watt	S1	Altec 12180-1
R14 ,15	220,000 ohms, ±10%, 1/2 watt	Rectifier	Sarkes-Tarzian 58-D
R16	34 ohms, ±1% (Dep. carbon)	V1	12AY7, Vacuum Tube
R17 ,R22	270,000 ohms, ±10%, 1/2 watt	V2	6BC8 Vacuum Tube
R18	33,000 ohms, ±10%, 1/2 watt	V3	6CG7 Vacuum Tube
R19	47,000 ohms, ±10%, 1/2 watt	V4	6AL5 Vacuum Tube

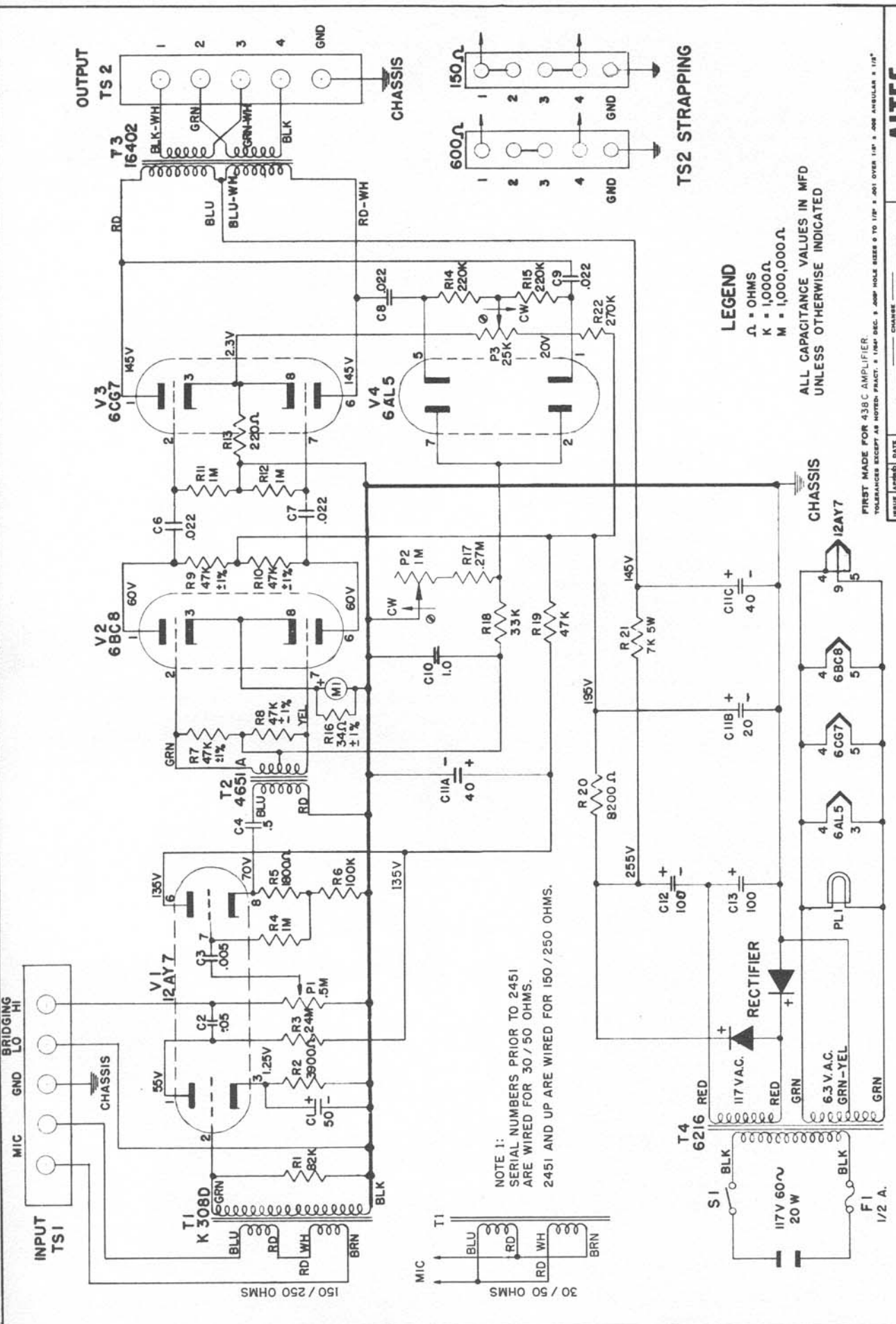

NOTE 1:
 SERIAL NUMBERS PRIOR TO 2451
 ARE WIRED FOR 30 / 50 OHMS.
 2451 AND UP ARE WIRED FOR 150 / 250 OHMS.

LEGEND
 Ω = OHMS
 K = 1,000Ω
 M = 1,000,000Ω
 ALL CAPACITANCE VALUES IN MFD
 UNLESS OTHERWISE INDICATED

FIRST MADE FOR 438C AMPLIFIER
 TOLERANCES EXCEPT AS NOTED: FRACT. & 1/8W DEC. & 1/2W DEC. & 1/4W OVER 1/8" & .001 OVER 1/16" & .001 OVER 1/32" & 1/16"

ISSUE	APPROVED	DATE	CHANGE
2		12-2-64	REVISED T1 WIRING TO T3, ADDED NOTE 1 & DETAIL

ALTEC
 ANAHEIM, CALIFORNIA
 SCHEMATIC
 438C AMPLIFIER
 DR BY M.M.JR 8195-2

ALTEC LANSING 438C COMPRESSOR AMPLIFIER